

Checking for Mismatched Ratios on Tandem Axles

Mismatched Tandem Axles

For a tandem axle pair to function correctly, the forward and rear axles must operate with axle ratios within one percent. A mismatched tandem axle pair can cause carrier overheating, hypoid gear set wear, metal debris to collect on the magnetic drain plug, carrier lubricant additive depletion, excessive interaxle wear and noise.

To determine if the tandem axle ratios operate within allowable limits, refer to one of the procedures included in this publication. Perform the procedure that will work best for the vehicle you are servicing.

For complete maintenance and service information on Meritor tandem axles, refer to the applicable maintenance manual:

- Maintenance Manual No. 5A, *Single Reduction Rear Differential Carriers*
- Maintenance Manual No. 5E, *Tandem Axle Forward Carriers and Single Axle Carrier*
- Maintenance Manual No. 5L, *Single Reduction Forward Differential Carriers on Tandem Axles*

To order copies of these publications, call Meritor's Customer Service Center at 800-535-5560.

Check the Hypoid Gear Set Ratios Listed on the Identification Tags

WARNING

To prevent serious eye injury, always wear safe eye protection when you perform vehicle maintenance or service.

1. Locate the identification tags riveted to the forward and rear axle differential carriers. **Figure 1.**

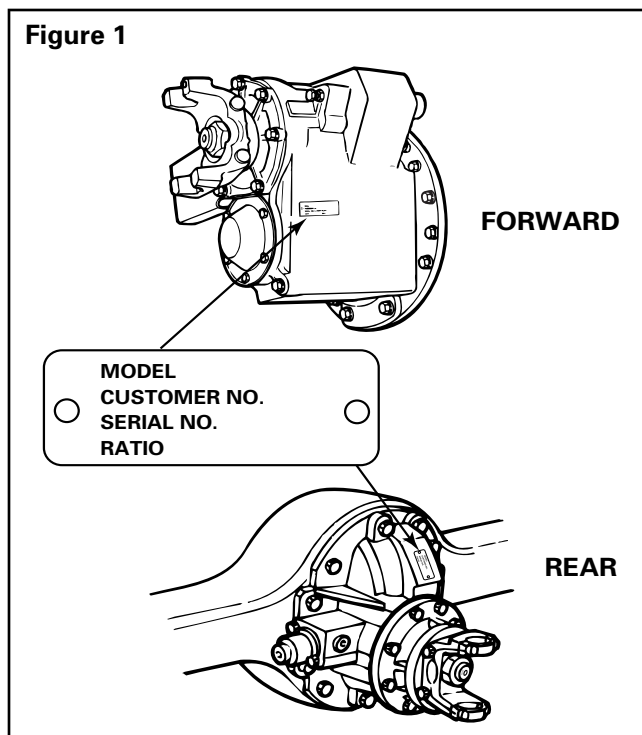

2. Compare the axle ratios shown on both tags. To operate correctly, the axle ratios for both axles must be within one percent of each other. To calculate the percentage difference between the axle ratios, refer to the equation below.

$$\frac{\text{Larger Ratio} - \text{Smaller Ratio}}{\text{Smaller Ratio}} \times 100 = \text{Percentage Difference Between Axle Ratios}$$

- **If the axle ratios shown on the identification tags are not within one percent of each other:** Refer to the vehicle manufacturer for further information.

Rotate the Forward Driveshaft to Check the Hypoid Gear Set Ratio

WARNING

Park the vehicle on a level surface. Block the wheels to prevent the vehicle from moving. Support the vehicle with safety stands. Do not work under a vehicle supported only by jacks. Jacks can slip and fall over. Serious personal injury can result.

1. Park the vehicle on a level surface.
2. Engage the power divider and shift the transmission into NEUTRAL.
3. Place blocks under the wheels to prevent the vehicle from moving.
4. Use a jack to raise the vehicle until all tandem drive axle wheels clear the ground. Support the vehicle with safety stands.
5. Mark the forward and rear tires at identical relative positions. **Figure 2.**

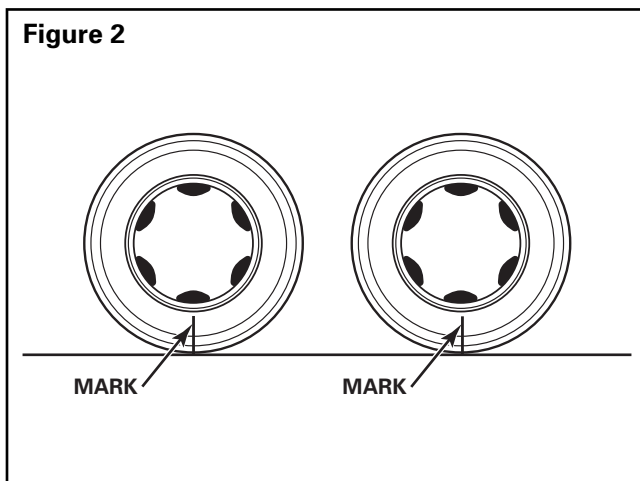

6. Turn the forward driveshaft in one direction by hand until the forward tire completes two rotations. Ensure that the forward tire rotates two times only. If the forward tire rotates more than or less than two rotations, the angle measurements you make in Step 7 will be inaccurate.

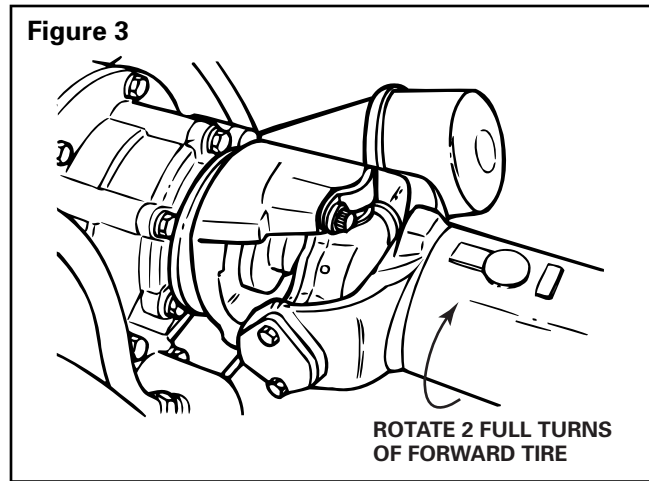

7. Note the positions of the tire marks you previously made. On a correctly matched tandem axle gear set, both tire marks will be within ± 3.6 degrees of each other. **Figure 4.**
 - **If the positions of the tire marks are more than 3.6 degrees from each other:** Refer to the vehicle manufacturer for further information.

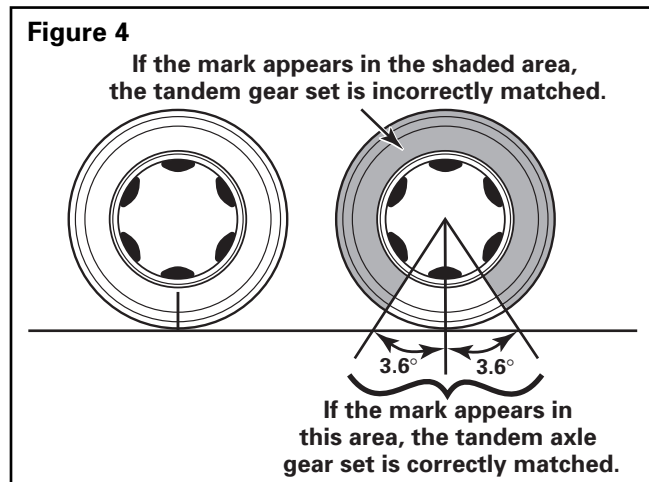

8. Remove the safety stands and lower the vehicle.

Check the Hypoid Gear Set Teeth Numbers Stamped on the Forward and Rear Axle Drive Pinions

When the interaxle driveline or differential carrier are removed for service, you can check the hypoid gear set teeth numbers stamped on the forward and rear axle drive pinions.

WARNING

Park the vehicle on a level surface. Block the wheels to prevent the vehicle from moving and serious personal injury.

1. Park the vehicle on a level surface.
2. Place blocks under the wheels to prevent the vehicle from moving.

To identify the gear teeth number on the forward axle drive pinion

1. Remove the forward carrier pinion cover. Refer to the vehicle manufacturer's procedures.
2. Look into the carrier housing. Identify and record the gear set teeth numbers stamped on the drive pinion end. **Figure 5.**
3. Calculate the hypoid gear set ratio by dividing the larger number by the smaller number. **Figure 5.**

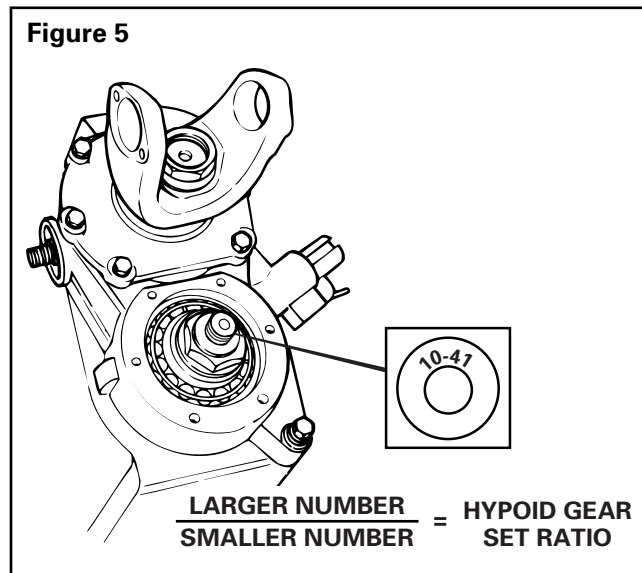

To identify the gear teeth number on the rear axle drive pinion

1. Remove the interaxle driveshaft. Refer to the vehicle manufacturer's procedures.
2. Identify and record the gear set teeth numbers stamped on the end of the rear axle drive pinion. **Figure 6.**
3. Calculate the hypoid gear set ratio by dividing the larger number by the smaller number. **Figure 6.**

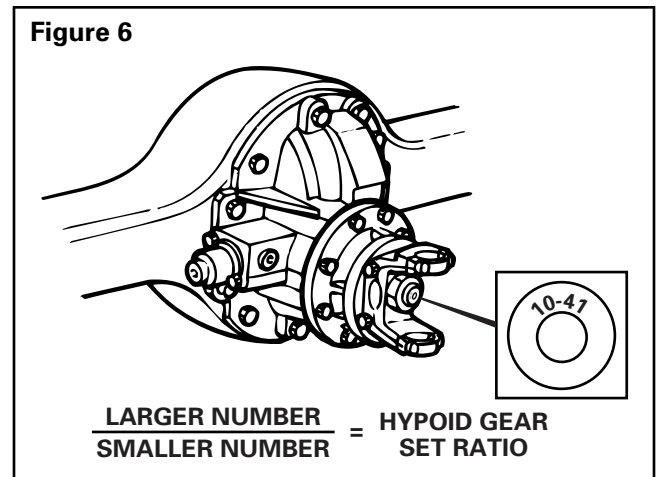

Compare both hypoid gear set ratios

1. Both ratios must be within one percent of each other. To calculate the percentage difference between the axle ratios refer to the equation below:

$$\frac{\text{Larger Ratio} - \text{Smaller Ratio}}{\text{Smaller Ratio}} \times 100 = \text{Percentage Difference Between Axle Ratios}$$

- **If the axle ratios shown on the identification tags are not within one percent of each other:** Refer to the vehicle manufacturer for further information.
2. Install the interaxle driveshaft. Refer to the vehicle manufacturer's procedures.
 3. Install the pinion cover. Refer to the vehicle manufacturer's procedures.
 4. Remove the safety stands and lower the vehicle.

Verify the Actual Hypoid Gear Set Ratios

You can check the actual hypoid gear set ratios when you remove the differential carriers from the axle housings for service or repair. Refer to the following procedure to calculate the actual gear set ratios.

1. Count the number of ring gear teeth. **Figure 7.**
2. Count the number of pinion gear teeth. **Figure 7.**
3. Divide the number of ring gear teeth by the number of pinion gear teeth to determine the actual hypoid gear set ratio for each axle. **Figure 7.**

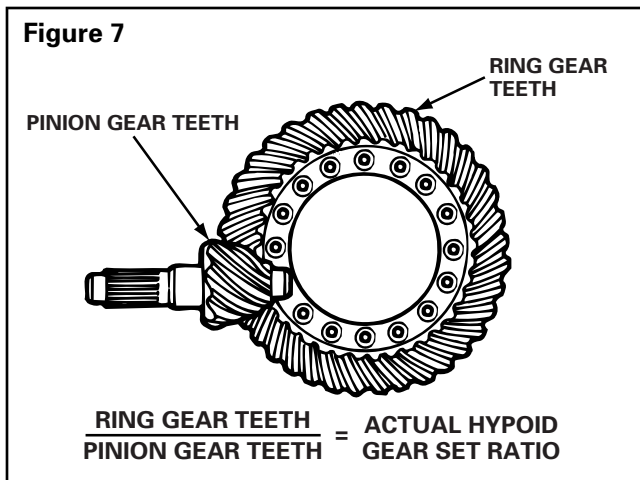

4. Calculate the percentage difference between the hypoid gear set ratios using the equation below. All ratios must match within one percent.

$$\frac{\text{Larger Ratio} - \text{Smaller Ratio}}{\text{Smaller Ratio}} \times 100 = \text{Percentage Difference Between Axle Ratios}$$

- **If the actual hypoid gear set ratios are not within one percent of each other:** Refer to the vehicle manufacturer for further information.



Meritor Heavy Vehicle Systems, LLC
2135 West Maple Road
Troy, MI 48084 USA
800-535-5560
www.meritorauto.com

Information contained in this publication was in effect at the time the publication was approved for printing and is subject to change without notice or liability. Meritor Heavy Vehicle Systems, LLC, reserves the right to revise the information presented or discontinue the production of parts described at any time.

© Copyright 1999
Meritor Automotive, Inc.
All Rights Reserved

Printed in the USA

TP-9998
Issued 10-99
16579/Meritor