

Single Reduction Drive Axle 71000 Series

For Transit Bus Applications

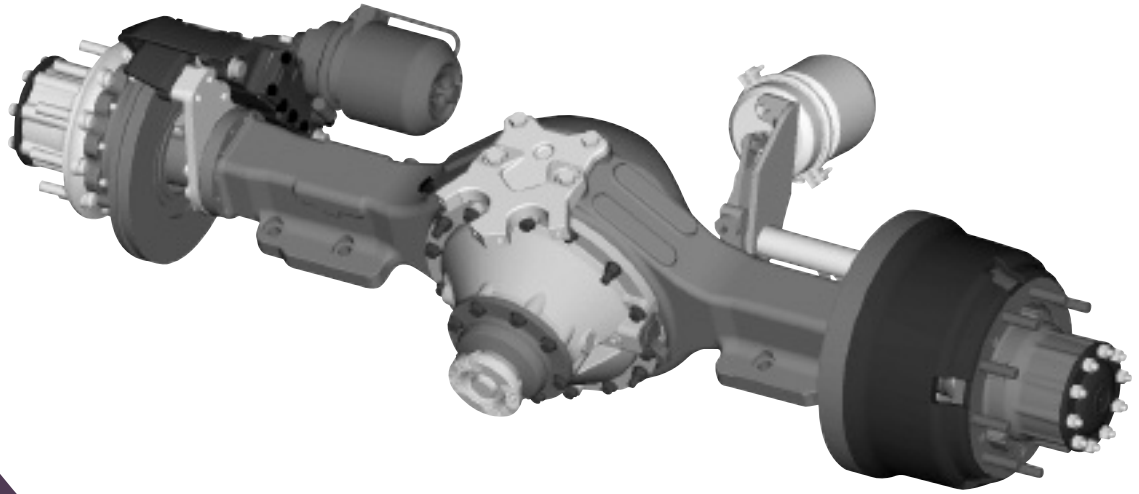

Product Summary

The Meritor®71000 Series axle is a new generation single reduction drive axle specifically built for the Transit Bus vocation. The new axle carries a 28,660 lb. (13.0 MT) gross axle weight rating (GAWR).

Several new features were incorporated in the 71000 Series design, including a one-piece cast iron housing with integral suspension bracket pads and “bolt-on” torque rod brackets. To improve the life of the seal and provide for easier set-up, a unitized wheel hub bearing with integrated seal has been added.

The R-177 carrier offers increased capacity, while maintaining the same overall size. And, the standard Cast Plus 16.5" x 8.625" S-cam, optional 14.5" x 10" “W” Series cam, or optional D-ELSA-2 air disc provide for brake flexibility.

The Meritor 71000 Series single reduction drive axle replaces the Meritor 61000 Series axle, an industry standard.

Application Summary

The 71000 Series axle is designed specifically for the North American Transit Bus market. For high start and stop duty cycle, demanding retarder loads and periodic axle overload applications, the Meritor 71000 Series is the perfect choice.

Optional - Air Disc Brake

- D-ELSA-2 calipers with larger wearable pad volume for longer life
- Visual wear indicator sensor; no wheel tear-down required
- Electronic wear sensor provides continuous wear rate output

Cast Plus™ 16.5"x 8.625" S-Cam Brake

- Cast shoes – stronger, less deflection, reusable
 - 360° anchor pins – maximum stability and fully lubricated
 - Precision-ground, extra thick lining block for maximum life
- "W" Series, 14.5"x 10" S-Cam Brake**
- Current industry standard Transit bus brake rated to 26K

Optional-Unitized Wheel End

- Wheel bearing pre-set, no adjustment required
- Sealed-for-life bearings
- Seals protected from damage during hub installation
- Precision seals integrated into bearing for long life

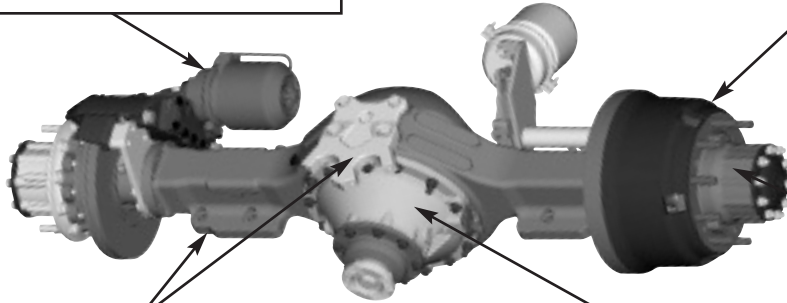

One-Piece Cast Iron Housing

- Integral leg & bowl brackets
- Bolt-on torque rod brackets
- Higher GAWR capacity 13 MT (28,660 lb.)
- Removable spindles, same as 61000 Series

R-177 Carrier

- Increased ring gear face width for longer life
- Higher capacity spigot bearing for demanding retarder loads
- "Pinion Pack" pinion bearings for easier rebuilds and improved pinion seal life
- Improved Ring gear-to-differential case joint (joint capacity increased by 44%)

Specifications: 71000 Series Single Reduction Drive Axle

GAWR RATING (MT)	HYPOID GEARSET PITCH DIA. INCHES (MM)	RATIOS	HOUSING SIZE / WALL THICKNESS	OVERALL INCHES (MM)	BRAKE TYPES AND SIZES		HUB AND DRUM BOLT CIRCLE DIA. INCHES (MM)
					S-CAM (STD.)	AIR DISC	
28,660 (13.0 MT)	18.0 (457.2)	4.10, 4.30, 4.56, 4.89, 5.38, 5.63, 6.14	VARIOUS CAST IRON	102 (2591 MM)	16.5" X 8.625" CAST PLUS (STD.) 14.5" X 10" "W" SERIES (OPT.)	D-ELSA-2	10 STUD 11.25 B.C. (285.75) "W" 14.5" X 10" BRAKE (HUB & STUD PILOT, STD. BEARING) 10 STUD 13.19 B.C. (335) CAST PLUS 16.5" X 8.625" BRAKE (HUB PILOT ONLY, STD. BEARING) UNITIZED WHEEL END 10 STUD 13.19 B.C. (335) (HUB PILOT ONLY)

Meritor Heavy Vehicle Systems, LLC

2135 West Maple Road
 Troy, MI 48084 USA
 800-535-5560
 arvinmeritor.com

Litho in U.S.A.

Copyright 2005
 ArvinMeritor, Inc.

Revised 10-05
 SP-0192r1005(47865/11900)

