

# MT-22

## Front Driving Axle

Extreme heavy-duty front drive axle for use in vocational AWD applications.

# Marmon-Herrington

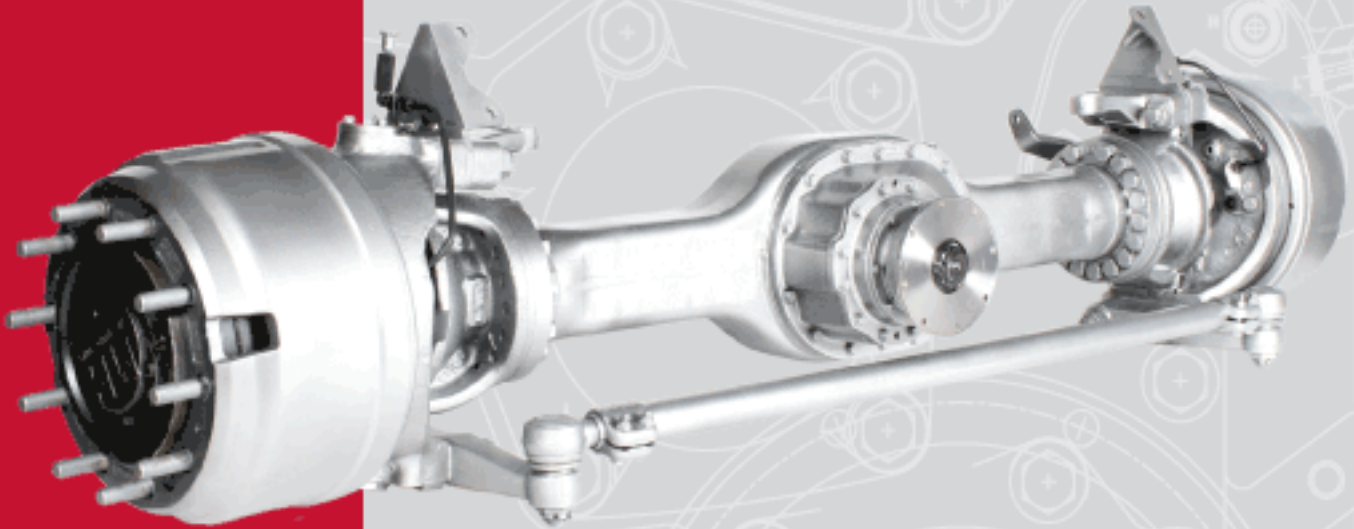

**Capacity (at ground):** 18,000 to 22,000#\*

**Reductions Available:** 4.25, 4.56, 4.92, 5.29, 5.38, 5.65, 5.83, 6.11, 6.27, 6.68, 7.14, 7.72, 8.36, 8.52

**Planetary Hub Reduction:** 3.461:1

**Axle Type:** Full-Floating Front-Driving Steering Axle

**Pinion Joint Series:** Spicer 1610, 1710, or 1810 / Meritor 161, 171, or 181 / SPL

**Steering Joint Type:** Double Cardan

**Axle Housing:** Steel Forging, 20.2 inch<sup>3</sup>S.M. @ Pad

**Crimp Angles:** 42°

**Camber:** 1/2°

**King-Pin Inclination:** 5 1/2°

**Toe-in:** 1/16" – 1/8"

**Wheel Mount:** Hub Piloted 335MM B.C., 10-Stud

**Wheel Mounting Distance:** 95"

**Track:** Approximately 81"

**Axle Mounting:** Spring Centers and Pad Width to Vehicle Requirements

**Approximate Axle Weight:** 2,050#

**Service Brakes:** 16 1/2" x 7" Air, S-Cam, Type 24 Chambers, Automatic Slack Adjusters Standard

**ABS Hub Compatibility:** Standard

**Input Rotation:** Counter Clockwise

### OPTIONS:

**Differential Lock:** Driver Controlled Limited-Slip Differential Lock

**Tire Inflation:** CTIS Compatible

\* (All applications must be approved by Marmon-Herrington Engineering)

Driving power since 1931.

**MT-22**

**Front Driving Axle**

Marmon-Herrington

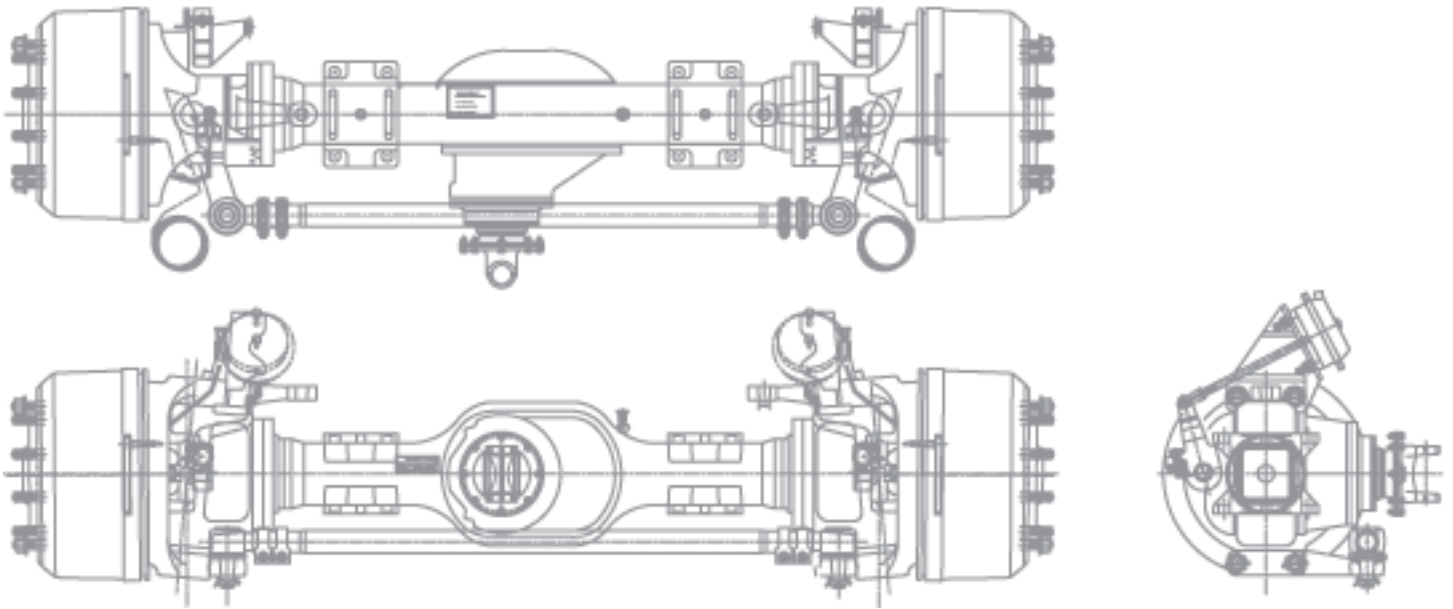

*\* For dimensional information, please contact Marmon-Herrington.*

**Marmon-Herrington:**

**A legacy of  
engineering  
excellence that  
lives on today.**

For over 75 years, Marmon-Herrington has been pioneering driving solutions that keep fleets moving and provide long-term value. Among our inventions: the Marmon Wasp, the first car ever to win the Indianapolis 500; double-cardan steering joints and low-profile differentials. Today, we're known for our full line of dependable axle systems

with premium components, product flexibility and best-in-class support.

Whether you're an OEM ready to outfit a fleet or a fleet manager looking for a kitting solution, Marmon-Herrington has the right system to get the job done and keep you moving. To learn more, call us at (800) 227-0727.

